

pulsIR[®] and *reflectIR*[™] Broadband Infrared Sources for use in Non-Dispersive Infrared Gas Benches

FEATURES:

- Broadband IR light from 2-20 μm
- Pulsed or DC operation
- Stable output
- Large temperature modulation in pulsed mode
- Many package and window options
- Available Evaluation Kit for rapid testing in existing systems





OVERVIEW:

Ion Optics offers a new class of electrically-pulsed, high intensity infrared radiators for gas analysis, spectroscopy and calibration. These radiators feature a low thermal-mass filament tailored for high emissivity. The filament is fabricated using a patented process that supplies more IR power output above 4 μm than traditional competing technologies. Thus the Ion Optics light sources can provide greater IR output while operating much cooler. This lower temperature operation reduces the chance of igniting combustible gasses, improves power efficiency, and reduces the parasitic heating of the optics and detectors.

Although these IR sources can be used for DC operation, they are typically pulsed at rates from 1/2 to 10 Hz allowing the design of smaller and simpler systems that do not require the added complexity of a mechanical chopper. Our low-thermal-mass design allows for quick warm-up and several hundred degrees of temperature modulation with each pulse.

For demonstration and system design, Ion Optics provides an Evaluation Kit, enabling users to explore radiator characteristics over a wide range of operating pulse parameters and filament temperatures. This Kit consists of an infrared source, microprocessor-controlled drive card, and Windows[™] compatible software. This system provides convenient selection of temperatures, frequencies, and duty cycles.

PART SELECTOR:

	Window			
	<i>No Window</i>	<i>Sapphire</i>	<i>Germanium*</i>	<i>Calcium Fluoride</i>
Package	2 – 20 μm^{∇}	2 – 5.25 μm^{∇}	7 – 12 μm^{∇}	2 – 9.5 μm^{∇}
 <i>T0-8</i>	NL8LNC NL8LNX NL8LNX-X	NM8ASC NM8ASB	Not Available	NL8ACC
 <i>T0-5</i>	NL5LNC	NM5NSC	NL5NGC	NL5NCC
 <i>Parabola</i>	reflectIR-P1N	reflectIR-P1S	Not Available	reflectIR-P1C

* with anti-reflection coating

∇ Range based on > 80% window transmission

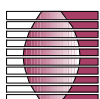

EVALUATION KIT:

The Evaluation Kit is designed to allow convenient experimentation with Ion Optics' family of infrared sources. The Evaluation Kit consists of: (a) a PC-controlled drive board producing a flat-topped current pulse of adjustable amplitude, length, and frequency; (b) Windows™ compatible software; and (c) the IR light source of your choosing. The kit can be run using dip selectable pre-programmed settings, or connected to a PC for user selection of temperature, pulse rate, and duty cycle.

TABLE OF CONTENTS:

TOPIC	Page #
Evaluation Kit	2
Ratings	2
Windows	2
Packages	3 - 4
Specifications	5 - 11
Application Notes	12 - 15

RATINGS:

Package	Rated Temp. (°C)	Max. Power*	Max. Voltage*	Max. Current*
T0-5	850	2.0 Watts	2.6 Volts	0.77 Amps
T0-8	850	2.25 Watts	2.81 Volts	0.80 Amps
Parabola	1000	1.7 Watts	1.75 Volts	0.97 Amps

* Max Power, Voltage, and Current based on typical resistance values.

WINDOWS:

Light sources are available with Sapphire, Anti reflection coated Germanium, Calcium Fluoride (CaF₂), or no window.

Window Type	Typical Properties				
	Thickness (mm)	Thickness (in)	Transmission(μm) [∇]	Peak Transmission	Ruggedness
Sapphire*	0.5	0.020	Vis. - 5.25	90% @ 4.5μm	High
Sapphire ⁺	0.25	0.010	Vis. - 5.25	90% @ 4.5μm	High
AR-Germanium	1.0	0.040	7 - 12	96% @ 9.5μm	High
Calcium Fluoride	1.0	0.040	Vis. - 9.5	94% @ 7μm	Medium
None	N/A	N/A	Vis. - ∞	100% @ all μm	N/A

* For T0-8 & T0-5 packages

⁺ For Parabolic reflector packages

[∇] Range based on > 80% transmission

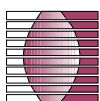
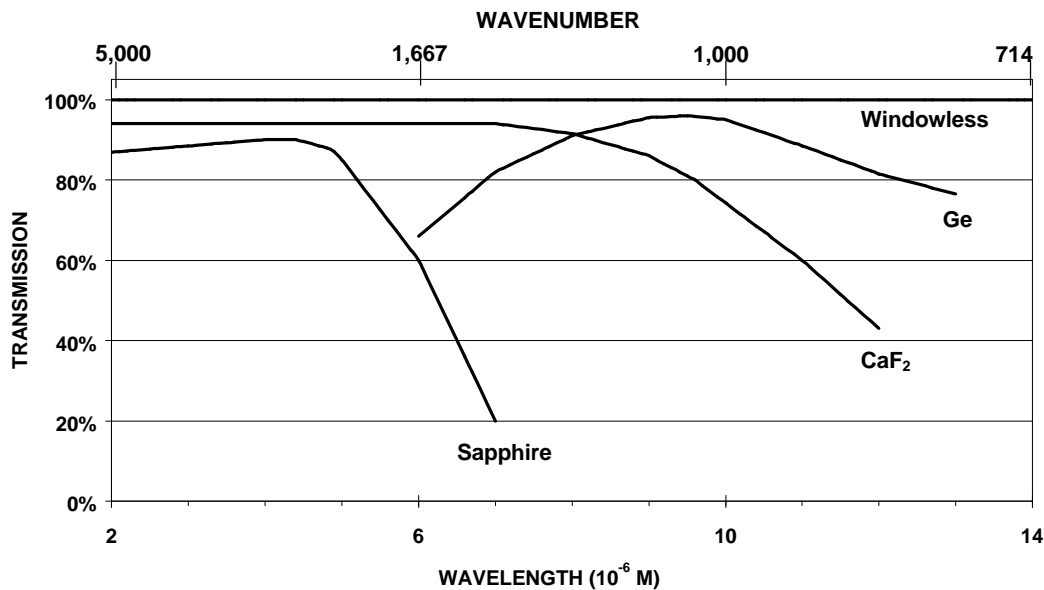

INFRARED LIGHT SOURCES

February 2000

NL5LNC, NL5NCC, NL5NGC, NM5NSC, NL8ACC, NL8LNC, NL8LNX
 NL8LNX-X, NM8ASB, NM8ASC, reflectIR-P1C, reflectIR-P1N, reflectIR-P1S

PACKAGES:

Light sources are available in 3 package types: T0-5, T0-8, and Parabolic. Details of each follow (dimensions in in.):



Package Drawing

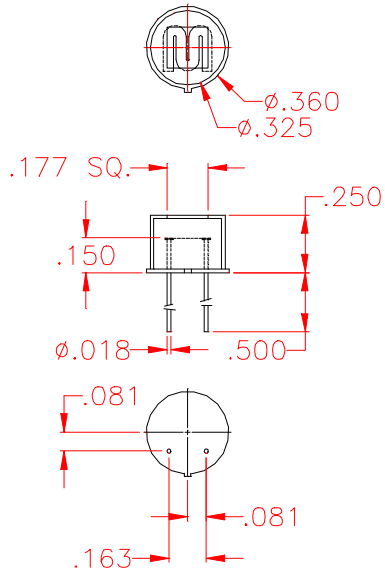

Normalized Output Pattern

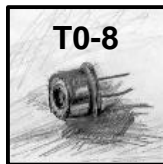
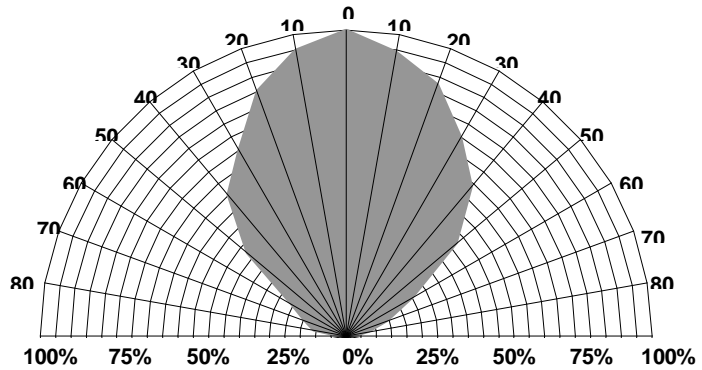

Package Drawing

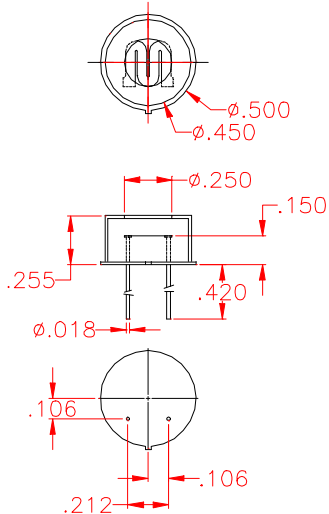

Normalized Output Pattern

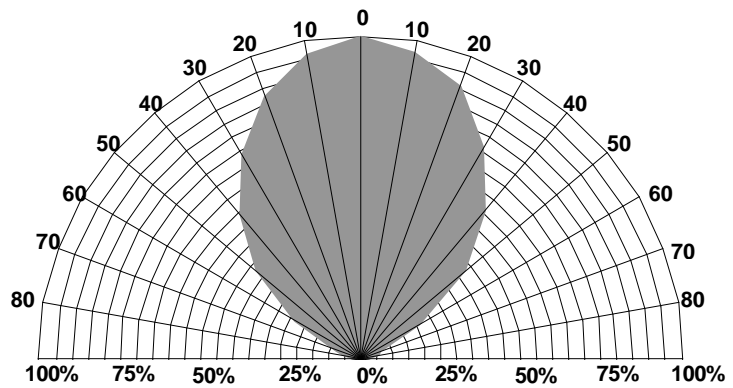

Ion Optics, Inc.

411 Waverley Oaks Rd, Suite 144,
 Waltham, MA 02452

Tel: (781) 788-8777
 FAX: (781) 788-8811
 URL: www.ion-optics.com

INFRARED LIGHT SOURCES

February 2000

NL5LNC, NL5NCC, NL5NGC, NM5NSC, NL8ACC, NL8LNC, NL8LNX
NL8LNX-X, NM8ASB, NM8ASC, reflectIR-P1C, reflectIR-P1N, reflectIR-P1S

PACKAGES (Cont'd)



Package Drawing

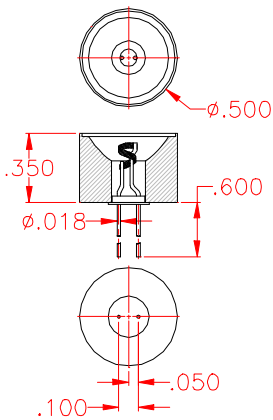

Normalized Output Pattern

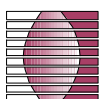
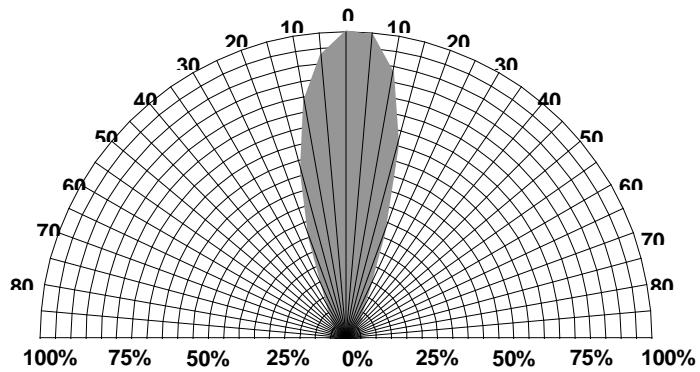

Ion Optics, Inc.

411 Waverley Oaks Rd, Suite 144,
Waltham, MA 02452

Tel: (781) 788-8777
FAX: (781) 788-8811
URL: www.ion-optics.com

SPECIFICATIONS:

T0-5 Packages

NL5LNC (T0-5, Windowless)		Min.	Typ.	Max.
 Mechanical	Package OD (in)	0.320	0.325	0.330
	Optical Aperture Size (in)	0.172 sq.	0.177 sq.	0.182 sq.
	Radiator Surface Area (mm ²)	-	21	-
Electrical	Electrical Resistance - Ω (at 25°C)	2.7	3.2	3.7
	Max. Input Power – W (for Typ. Ω)	-	-	2.0
	Max. Input Voltage – V (for Typ. Ω)	-	-	2.6
	Max. Input Current – A (for Typ. Ω)	-	-	0.77
Optical	Window Thickness (in)	-	-	-
	Output Wavelength (μm)	Vis.	-	20
	Output Cone ⁺	-	100°	-
	Peak Surface Temperature (°C) [⊗]	-	-	850
	Temperature Modulation (°C)	-	-	500
	Life (Yrs.) [∇]	-	6	-

- ⁺ Full angle for 50% of peak power, see page 3 package charts for details.
- [⊗] Temperature at hottest point of surface when operated at maximum rated power.
- [∇] See applications note #4.

NL5NCC (T0-5, Calcium Fluoride)		Min.	Typ.	Max.
 Mechanical	Package OD (in)	0.320	0.325	0.330
	Optical Aperture Size (in)	0.172 sq.	0.177 sq.	0.182 sq.
	Radiator Surface Area (mm ²)	-	21	-
Electrical	Electrical Resistance - Ω (at 25°C)	2.7	3.2	3.7
	Max. Input Power – W (for Typ. Ω)	-	-	2.0
	Max. Input Voltage – V (for Typ. Ω)	-	-	2.6
	Max. Input Current – A (for Typ. Ω)	-	-	0.77
Optical	Window Thickness (in)	0.035	0.040	0.045
	Output Wavelength (μm) [*]	Vis.	-	9.5
	Output Cone ⁺	-	100°	-
	Peak Surface Temperature (°C) [⊗]	-	-	850
	Temperature Modulation (°C)	-	-	500
	Life (Yrs.) [∇]	-	6	-

- ^{*} For >80% window transmission. See page 2 Window curves for details.
- ⁺ Full angle for 50% of peak power, see page 3 package charts for details.
- [⊗] Temperature at hottest point of surface when operated at maximum rated power.
- [∇] See applications note #4.

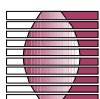

T0-5 Packages (Cont'd)

NL5NGC (T0-5, Germanium)		Min.	Typ.	Max.
	Package OD (in)	0.320	0.325	0.330
	Optical Aperture Size (in)	0.172 sq.	0.177 sq.	0.182 sq.
	Radiator Surface Area (mm ²)	-	21	-
Electrical	Electrical Resistance - Ω (at 25°C)	2.7	3.2	3.7
	Max. Input Power – W (for Typ. Ω)	-	-	2.0
	Max. Input Voltage – V (for Typ. Ω)	-	-	2.6
	Max. Input Current – A (for Typ. Ω)	-	-	0.77
Optical	Window Thickness (in)	0.035	0.040	0.045
	Output Wavelength (μm)*	7	-	12
	Output Cone ⁺	-	100°	-
	Peak Surface Temperature (°C) [⊗]	-	-	850
	Temperature Modulation (°C)	-	-	500
	Life (Yrs.) [∇]	-	6	-

* For >80% window transmission. See page 2 Window curves for details.

+ Full angle for 50% of peak power, see page 3 package charts for details.

⊗ Temperature at hottest point of surface when operated at maximum rated power.

∇ See applications note #4.

NM5NSC (T0-5, Sapphire)		Min.	Typ.	Max.
	Package OD (in)	0.320	0.325	0.330
	Optical Aperture Size (in)	0.172 sq.	0.177 sq.	0.182 sq.
	Radiator Surface Area (mm ²)	-	21	-
Electrical	Electrical Resistance - Ω (at 25°C)	2.7	3.2	3.7
	Max. Input Power – W (for Typ. Ω)	-	-	2.0
	Max. Input Voltage – V (for Typ. Ω)	-	-	2.6
	Max. Input Current – A (for Typ. Ω)	-	-	0.77
Optical	Window Thickness (in)	0.015	0.020	0.025
	Output Wavelength (μm)*	Vis.	-	5.25
	Output Cone ⁺	-	100°	-
	Peak Surface Temperature (°C) [⊗]	-	-	850
	Temperature Modulation (°C)	-	-	500
	Life (Yrs.) [∇]	-	6	-

* For >80% window transmission. See page 2 Window curves for details.

+ Full angle for 50% of peak power, see page 3 package charts for details.

⊗ Temperature at hottest point of surface when operated at maximum rated power.

∇ See applications note #4.

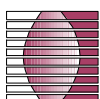

T0-8 Packages

NL8ACC (T0-8, Calcium Fluoride)		Min.	Typ.	Max.
Mechanical 	Package OD (in)	0.445	0.450	0.455
	Optical Aperture Size (in)	0.245	0.250	0.255
	Radiator Surface Area (mm ²)	-	28	-
Electrical	Electrical Resistance - Ω (at 25°C)	3.0	3.5	4.0
	Max. Input Power – W (for Typ. Ω)	-	-	2.25
	Max. Input Voltage – V (for Typ. Ω)	-	-	2.81
	Max. Input Current – A (for Typ. Ω)	-	-	0.80
Optical	Window Thickness (in)	0.035	0.040	0.045
	Output Wavelength (μm)*	Vis.	-	9.5
	Output Cone ⁺	-	90°	-
	Peak Surface Temperature (°C) [⊗]	-	-	850
	Temperature Modulation (°C)	-	-	500
	Life (Yrs.) [▽]	-	6	-

- * For >80% window transmission. See page 2 Window curves for details.
- + Full angle for 50% of peak power, see page 3 package charts for details.
- ⊗ Temperature at hottest point of surface when operated at maximum rated power.
- ▽ See applications note #4.

NL8LNC (T0-8, No Window)		Min.	Typ.	Max.
Mechanical 	Package OD (in)	0.445	0.450	0.455
	Optical Aperture Size (in)	0.245	0.250	0.255
	Radiator Surface Area (mm ²)	-	28	-
Electrical	Electrical Resistance - Ω (at 25°C)	3.0	3.5	4.0
	Max. Input Power – W (for Typ. Ω)	-	-	2.25
	Max. Input Voltage – V (for Typ. Ω)	-	-	2.81
	Max. Input Current – A (for Typ. Ω)	-	-	0.80
Optical	Window Thickness (in)	-	-	-
	Output Wavelength (μm)	Vis.	-	20
	Output Cone ⁺	-	90°	-
	Peak Surface Temperature (°C) [⊗]	-	-	850
	Temperature Modulation (°C)	-	-	500
	Life (Yrs.) [▽]	-	6	-

- + Full angle for 50% of peak power, see page 3 package charts for details.
- ⊗ Temperature at hottest point of surface when operated at maximum rated power.
- ▽ See applications note #4.

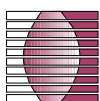

T0-8 Packages (Cont'd)

NL8LNX	(T0-8, No Window, Wide W)	Min.	Typ.	Max.
	Package OD (in)	0.445	0.450	0.455
	Optical Aperture Size (in)	0.245	0.250	0.255
	Radiator Surface Area (mm ²)	-	28	-
Electrical	Electrical Resistance - Ω (at 25°C)	2.8	3.5	4.5
	Max. Input Power – W (for Typ. Ω)	-	-	2.25
	Max. Input Voltage – V (for Typ. Ω)	-	-	2.81
	Max. Input Current – A (for Typ. Ω)	-	-	0.80
Optical	Window Thickness (in)	-	-	-
	Output Wavelength (μm)	Vis.	-	20
	Output Cone ⁺	-	90°	-
	Peak Surface Temperature (°C) [⊗]	-	-	850
	Temperature Modulation (°C)	-	-	500
	Life (Yrs.) [▽]	-	6	-

- ⁺ Full angle for 50% of peak power, see page 3 package charts for details.
- [⊗] Temperature at hottest point of surface when operated at maximum rated power.
- [▽] See applications note #4.

NL8LNX-N	(T0-8, No Window, No Cap, Wide W)	Min.	Typ.	Max.
	Package OD (in)	-	-	-
	Optical Aperture Size (in)	-	-	-
	Radiator Surface Area (mm ²)	-	28	-
Electrical	Electrical Resistance - Ω (at 25°C)	2.8	3.5	4.5
	Max. Input Power – W (for Typ. Ω)	-	-	2.25
	Max. Input Voltage – V (for Typ. Ω)	-	-	2.81
	Max. Input Current – A (for Typ. Ω)	-	-	0.80
Optical	Window Thickness (in)	-	-	-
	Output Wavelength (μm)	Vis.	-	20
	Output Cone ⁺	-	120°	-
	Peak Surface Temperature (°C) [⊗]	-	-	850
	Temperature Modulation (°C)	-	-	500
	Life (Yrs.) [▽]	-	6	-

- ⁺ Full angle for 50% of peak power, see page 3 package charts for details.
- [⊗] Temperature at hottest point of surface when operated at maximum rated power.
- [▽] See applications note #4.

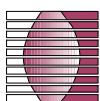

T0-8 Packages (Cont'd)

NM8ASB (T0-8, Sapphire, Narrow W)		Min.	Typ.	Max.
 Mechanical	Package OD (in)	0.445	0.450	0.455
	Optical Aperture Size (in)	0.245	0.250	0.255
	Radiator Surface Area (mm ²)	-	28	-
Electrical	Electrical Resistance - Ω (at 25°C)	3.3	3.5	3.7
	Max. Input Power – W (for Typ. Ω)	-	-	2.25
	Max. Input Voltage – V (for Typ. Ω)	-	-	2.81
	Max. Input Current – A (for Typ. Ω)	-	-	0.80
Optical	Window Thickness (in)	0.015	0.020	0.025
	Output Wavelength (μm)*	Vis.	-	5.25
	Output Cone ⁺	-	90°	-
	Peak Surface Temperature (°C) [⊗]	-	-	850
	Temperature Modulation (°C)	-	-	500
	Life (Yrs.) [∇]	-	6	-

- * For >80% window transmission. See page 2 Window curves for details.
- + Full angle for 50% of peak power, see page 3 package charts for details.
- ⊗ Temperature at hottest point of surface when operated at maximum rated power.
- ∇ See applications note #4.

NM8ASC (T0-8, Sapphire)		Min.	Typ.	Max.
 Mechanical	Package OD (in)	0.445	0.450	0.455
	Optical Aperture Size (in)	0.245	0.250	0.255
	Radiator Surface Area (mm ²)	-	28	-
Electrical	Electrical Resistance - Ω (at 25°C)	3.0	3.5	4.0
	Max. Input Power – W (for Typ. Ω)	-	-	2.25
	Max. Input Voltage – V (for Typ. Ω)	-	-	2.81
	Max. Input Current – A (for Typ. Ω)	-	-	0.80
Optical	Window Thickness (in)	0.015	0.020	0.025
	Output Wavelength (μm)*	Vis.	-	5.25
	Output Cone ⁺	-	90°	-
	Peak Surface Temperature (°C) [⊗]	-	-	850
	Temperature Modulation (°C)	-	-	500
	Life (Yrs.) [∇]	-	6	-

- * For >80% window transmission. See page 2 Window curves for details.
- + Full angle for 50% of peak power, see page 3 package charts for details.
- ⊗ Temperature at hottest point of surface when operated at maximum rated power.
- ∇ See applications note #4.

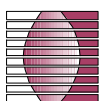

Parabola Packages

ReflectIR-P1C (<i>Parabola, Calcium Fluoride</i>)		Min.	Typ.	Max.
Mechanical 	Package OD (in)	0.495	0.500	0.505
	Optical Aperture Size (in)	0.427	0.432	0.437
	Radiator Surface Area (mm ²)	-	11.35	-
Electrical	Electrical Resistance - Ω (at 25°C)	1.5	1.8	2.0
	Max. Input Power – W (for Typ. Ω)	-	-	1.7
	Max. Input Voltage – V (for Typ. Ω)	-	-	1.75
	Max. Input Current – A (for Typ. Ω)	-	-	0.97
Optical	Window Thickness (in)	0.035	0.040	0.045
	Output Wavelength (μm)*	Vis.	-	9.5
	Output Cone ⁺	-	30°	-
	Peak Surface Temperature (°C) [⊗]	-	-	1000
	Temperature Modulation (°C)	-	-	800
	Life (Yrs.) [∇]	-	6	-

- * For >80% window transmission. See page 2 Window curves for details.
- + Full angle for 50% of peak power, see page 3 package charts for details.
- ⊗ Temperature at hottest point of surface when operated at maximum rated power.
- ∇ See applications note #4.

ReflectIR-P1N (<i>Parabola, No Window</i>)		Min.	Typ.	Max.
Mechanical 	Package OD (in)	0.495	0.500	0.505
	Optical Aperture Size (in)	0.427	0.432	0.437
	Radiator Surface Area (mm ²)	-	11.35	-
Electrical	Electrical Resistance - Ω (at 25°C)	1.5	1.8	2.0
	Max. Input Power – W (for Typ. Ω)	-	-	1.7
	Max. Input Voltage – V (for Typ. Ω)	-	-	1.75
	Max. Input Current – A (for Typ. Ω)	-	-	0.97
Optical	Window Thickness (in)	-	-	-
	Output Wavelength (μm)	Vis.	-	20
	Output Cone ⁺	-	30°	-
	Peak Surface Temperature (°C) [⊗]	-	-	1000
	Temperature Modulation (°C)	-	-	800
	Life (Yrs.) [∇]	-	6	-

- + Full angle for 50% of peak power, see page 3 package charts for details.
- ⊗ Temperature at hottest point of surface when operated at maximum rated power.
- ∇ See applications note #4.

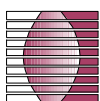

Parabola Packages (Cont'd)

ReflectIR-P1S (<i>Parabola, Sapphire</i>)		Min.	Typ.	Max.
Mechanical 	Package OD (in)	0.495	0.500	0.505
	Optical Aperture Size (in)	0.427	0.432	0.437
	Radiator Surface Area (mm ²)	-	11.35	-
Electrical	Electrical Resistance - Ω (at 25°C)	1.5	1.8	2.0
	Max. Input Power – W (for Typ. Ω)	-	-	1.7
	Max. Input Voltage – V (for Typ. Ω)	-	-	1.75
	Max. Input Current – A (for Typ. Ω)	-	-	0.97
Optical	Window Thickness (in)	0.008	0.010	0.012
	Output Wavelength (μm)*	Vis.	-	5.25
	Output Cone ⁺	-	30°	-
	Peak Surface Temperature (°C) [⊗]	-	-	1000
	Temperature Modulation (°C)	-	-	800
	Life (Yrs.) [∇]	-	6	-

* For >80% window transmission. See page 2 Window curves for details.

+ Full angle for 50% of peak power, see page 3 package charts for details.

⊗ Temperature at hottest point of surface when operated at maximum rated power.

∇ See applications note #4.

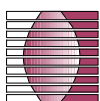

APPLICATIONS

1. Pulsed Operation

For most applications, filaments should be run at duty cycles of less than 50%. Although capable of running at duty cycles of up to 100 % (DC), the loss of temperature modulation with increasing duty/frequency generally reduces the utility of the device for most applications.

Generally, square-waveform constant current or constant voltage drive schemes are the simplest and most cost effective means of powering the sources. For constant current drivers, the power delivered to the source goes as I^2R . As the source heats up, its resistance increases slightly, causing the power delivered to the source to increase during the "ON" portion of a pulse. For constant voltage drivers, delivered power goes as V^2/R ; therefore the power delivered to the source tends to decrease slightly during the length of a pulse. Other drive schemes can also be employed; constant power or DC for example.

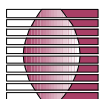

3. Ballast Resistors

Ballast resistors are a means of converting a constant voltage (CV) or constant current (CC) drive scheme into a “poor man’s” constant power drive. Although not a true constant power system, a CV or CC driver in conjunction with a ballast resistor can greatly reduce the effect of source resistance on power output.

Advantage: Increased output stability

Disadvantage: Increased power consumption

Constant Voltage:

The energy delivered to a resistive load in a constant voltage system goes as:

$$P = V^2/R$$

i.e. the power delivered to the load varies inversely with load resistance. However, by inserting a series ballast resistor, the power delivered to the load still varies inversely with its resistance, but the voltage drop across the load (now a function of the ratio of the load resistance to the sum of the load and ballast resistances) shifts in the other direction, to a large extent canceling out the effect. The graph to the right shows the affect of a 3.5Ω ballast resistor placed in series with a pulsIR source connected to a 4 volt constant drive. Note that the “with” and “without” ballast plots use different vertical scales with the same gain.

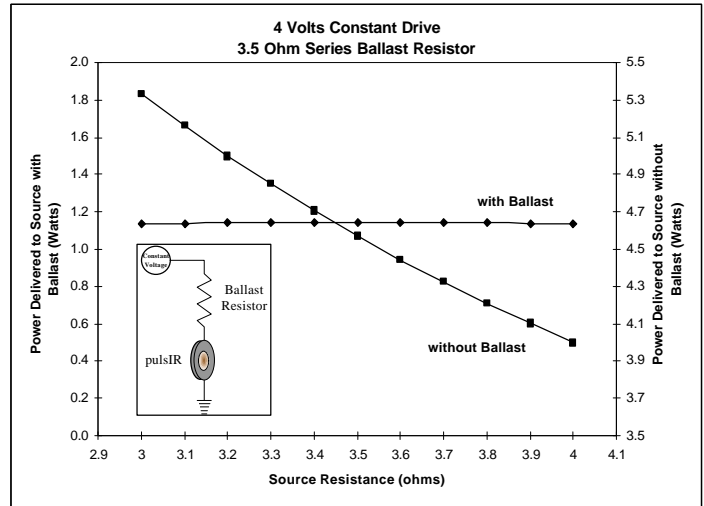

Constant Current:

The energy delivered to a resistive load in a constant current system goes as:

$$P = I^2R$$

i.e. the power delivered to the load varies with load resistance. Similar to the constant voltage drive system, the presence of a parallel ballast resistor causes the delivered power to be relatively unaffected by large changes in load resistance. The graph to the right shows the corresponding delivered power vs. load resistance for a constant current setup. Note that the “with” and “without” ballast plots use different vertical scales with the same gain.

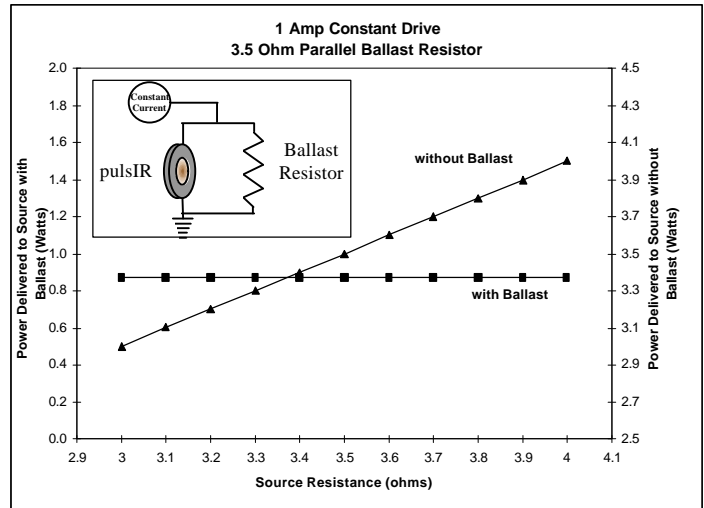

4. Source Lifetime

The following graph shows the results (to date) from an ongoing extended life test experiment using an Ion Optics NM8ASC source. The source is being driven by a constant current drive board at 1 Hz, 30% duty cycle at an approximate temperature of 650°C. Two pyroelectric detectors are monitoring the source output at two distinct wavelengths. In the following chart, the circles show the source output at 4.29 microns (CO₂) while the diamonds show the output at 3.9 microns (reference). The detectors are mounted about four inches from the front face of the source and a dry nitrogen purge is used to prevent water vapor and carbon dioxide in the lab air from affecting the measurement. The temperature in the lab is not very well controlled however, and much of the variation (specifically the bump at ≈2000 hours) is due to room temperature swings.

The definition of failure, and thus the definition of lifetime, is very subjective as each system has unique sensitivity to drift (largely related to the A/D bandwidth). We have encountered several applications which define failure as >15% drift from the original power level, so we will adopt this definition for the purposes of this computation. The graph below shows that the median signal level from the 3.9 and 4.29 μm detectors is roughly 4 volts; the linear regression fits to the raw data indicate that both of these signals are decreasing at a rate of 1x10⁻⁵ volts/hour. With our assumed signal drift tolerance of 15% and 4 volt signal level, we require a 0.6 volt signal change to signal failure of the light source [0.15 x 4]. With our measured rate of change being 1x10⁻⁵ volts/hour it will take approximately **6.85 years** of continuous operation to obtain a 15% signal change [(0.6v)/(1x10⁻⁵v/hr)/(8760hrs/yr)]. Since many systems utilize the ratio of the gas measurement to a reference, they are sensitive not to signal changes, but to change in the ratio of the two signals. With a measured slope of 1x10⁻⁶ volts/hour and a 0.75 volt signal the same computation yields a lifetime of **12.84 years**.

Since all of the known filament degradation mechanisms are temperature dependent, the time to 15% failure is strongly dependent upon operating temperature or electrical power applied. Therefore, caution should be used in extrapolating these results to your application.

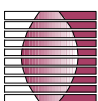
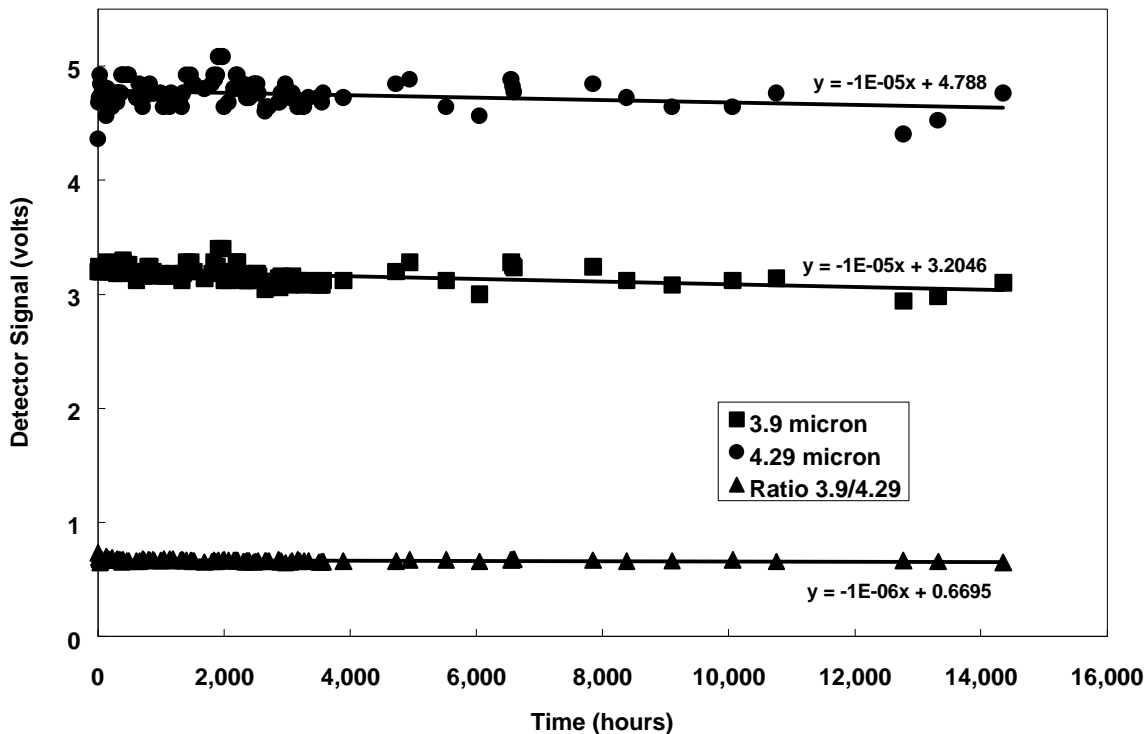

5. Shot-to-Shot stability

Owing to the extremely low thermal mass of pulsIR emitters, shot-to-shot stability is directly related to drive circuit stability. Variations in drive pulses will translate into variations in output. To determine this we used a liquid nitrogen cooled InSb detector available in our laboratory for detecting energy in the 2-5 μm range. The pulsIR source was driven with a specially-designed constant-voltage drive circuit that ensures pulse-to-pulse repeatability (standard deviation) of 5.3×10^{-4} . Measurements of the InSb detector reading from 16 seconds of 10 Hz operation was measured to have a comparable standard deviation of 6.8×10^{-4} .

6. Spatial Uniformity and Color Stability

Spatial uniformity and color stability were characterized using an Amber 3-5 μm imaging radiometer. The images below show typical data collected. The two images are from adjacent pulse plateaus. The third image shows the digital difference of the measured radiance of the two. The radiance difference data was analyzed and a histogram was created showing pulse to pulse repeatability. The surface plot shows the image pixel plane with the vertical axis indicating absolute signal difference in "counts" proportional to detected intensity. The histogram shows that this variation is on average seven counts out of a possible 3500 counts.

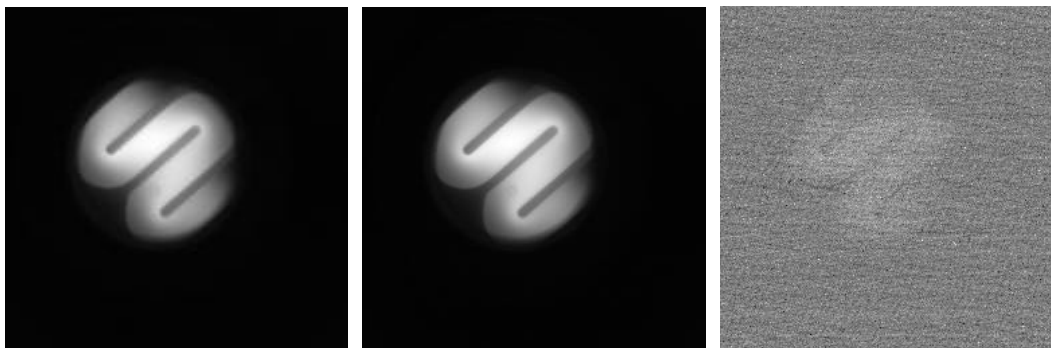
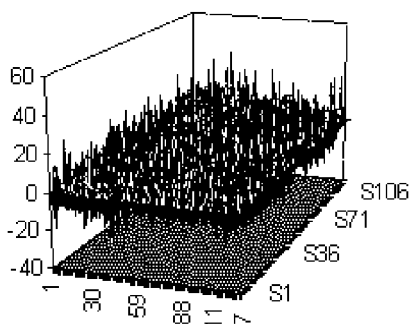

IMAGE - IMAGE PIXEL VARIATION



DISTRIBUTION FOR CONSTANT CURRENT

